

浸透角柵承認図

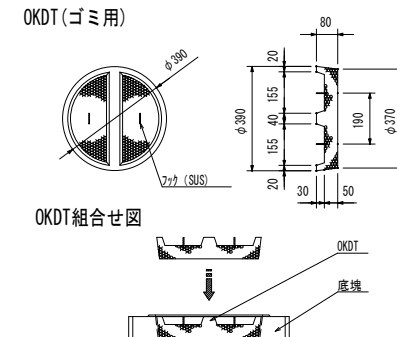
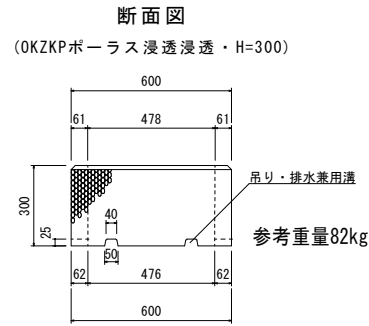
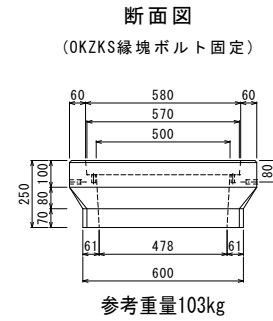
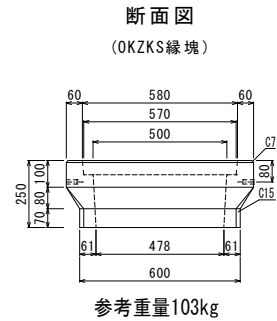
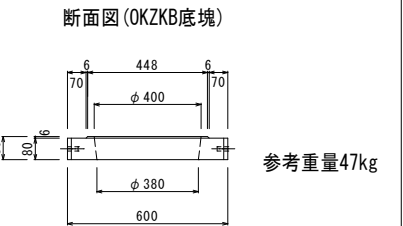
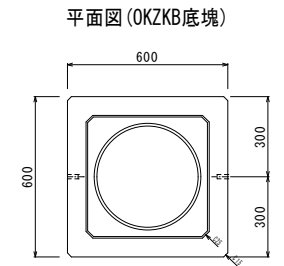
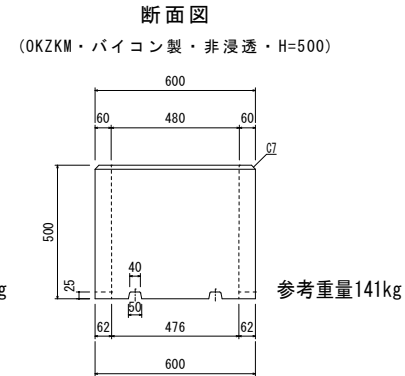
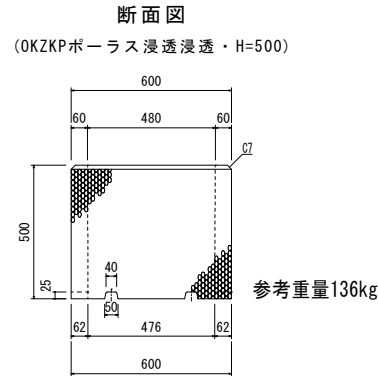
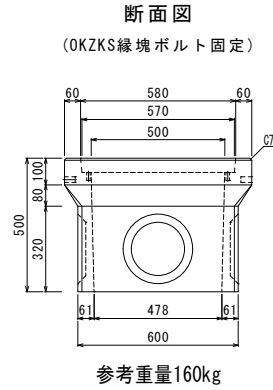
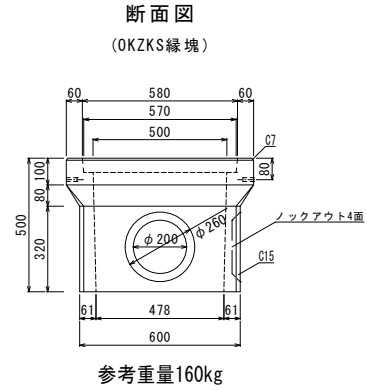
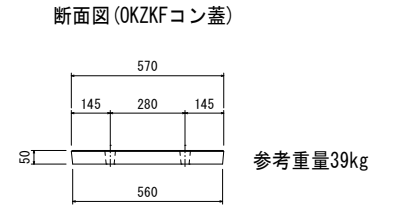
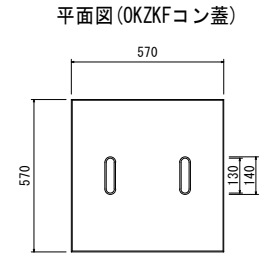
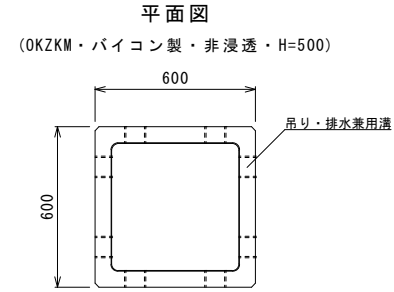
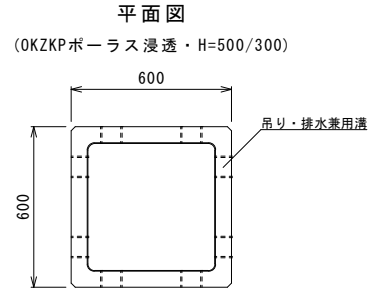
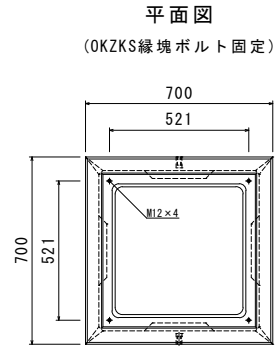
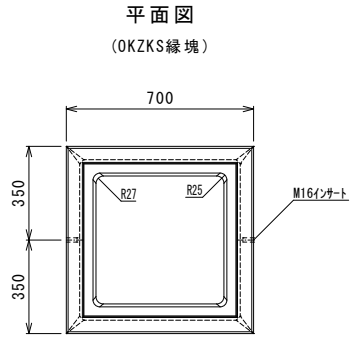

品名	OK式浸透角柵 500			
承認	検図	設計	縮尺	1/20
株式会社 オーイーケ				図番 OKZK500